

PLAIN TALKS

DECEMBER, 1949

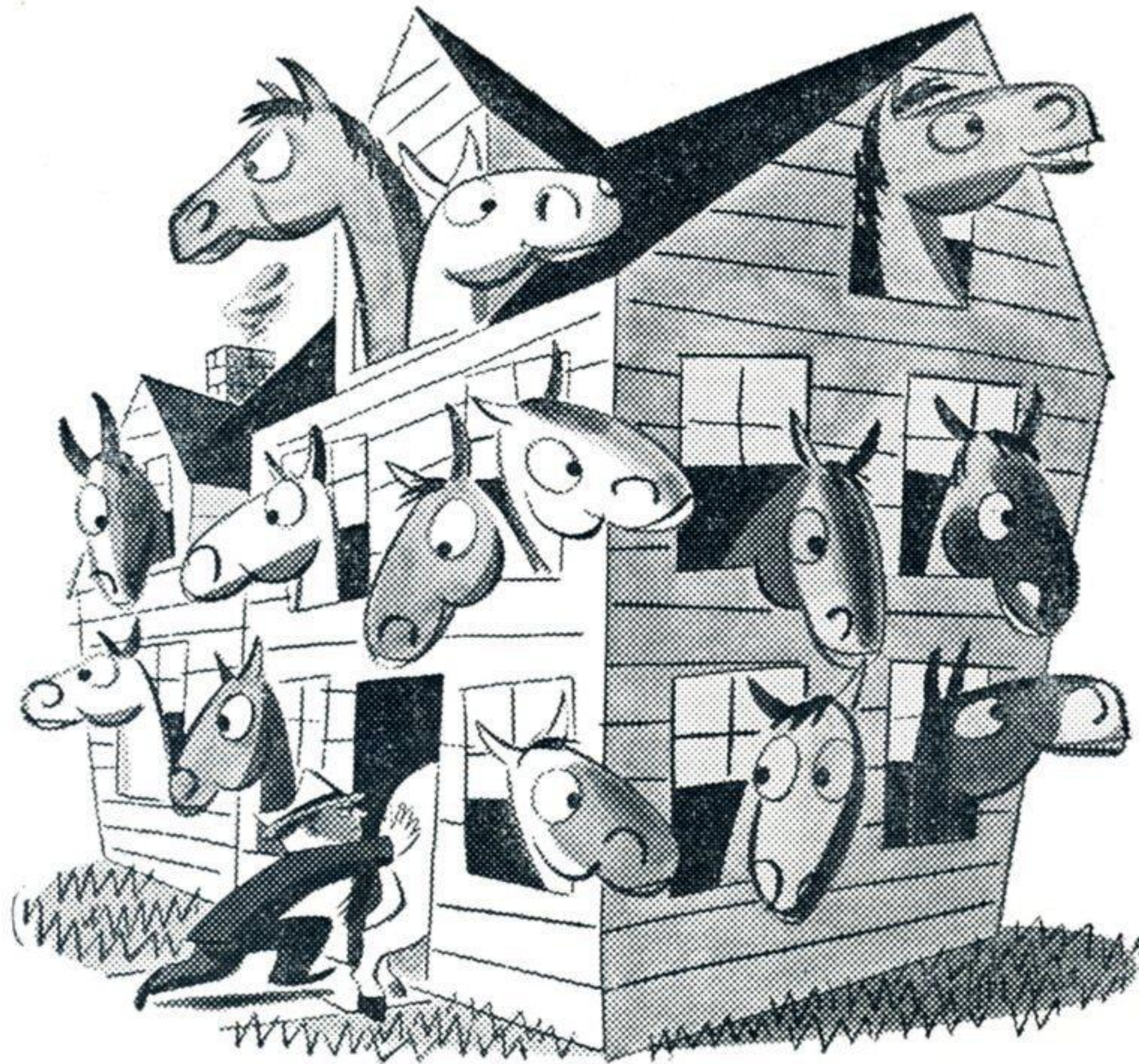

Uncle Horace filled his house with horses



HE figured to run his house by horse power instead of electric power. No more electric bills for him!

So he hitched Dobbin to the washing machine, and old Nell to the refrigerator. Bought another nag for the vacuum cleaner and more for the other jobs.

Poor Horace! All he got was a hate for horseflesh and a hatful of debts. — But a great love for his electric bills!

And why not? Electric power is about the handiest, quickest, easiest way to get work done. And

about the cheapest . . . what else can a person buy that does so erage family in a day uses electric much, yet costs so little? (An av-power equal to the work of 5 or 6 horses—and buys it for a few pennies!)

That's good business for anybody who has housework—or almost any kind of of work—to get done. *Business*-managed electric companies like ours have made it that way. By pioneering electric service. By showing people how useful it is. By finding ways to make it the best bargain in a family's budget.

PLAIN TALKS

A magazine for employees of
Gulf States Utilities Company

Vol. 27 No. 5



Dec., 1949

Editor—Kenneth Sutton
Managing Editor—Jerry Stokes
Associate Editors—Joe DeJean, Jack Burhoe
Art Editor—Roy Keller

REPORTERS

BATON ROUGE DIVISION

Glense Chustz.....Baton Rouge General Office
Julia Marie Amrhein.....Electric Dept.
Miner Fugler.....Gas Dept.
Ella Bee Andre'.....Louisiana Station

BEAUMONT DIVISION

J. Roy Peckham.....Alvin District
Violet Maxwell.....Beaumont General Office
Tom Stiteler.....Beaumont Line
Rose Annie Ray.....Beaumont T & D
Tennie DeVore.....Liberty District
Naomi Haynes.....Neches Station
Dick Eddleman.....Orange District
Bruce McClelland.....Sabine Station
Lois Day.....Silsbee District

LAKE CHARLES DIVISION

Melvin Garman.....Jennings District
Barbara M. Artigue.....Lafayette District
Fay Denney.....Lake Charles Division
Betty Guidry.....Lake Charles T & D
E. C. McGehee.....Riverside Station
Ana Mae LeDoux.....Sulphur District

NAVASOTA DIVISION

Alma Greathouse.....Caldwell District
Louise Satory.....Calvert District
Jean Wallace.....Cleveland District
Raymond T. Wright.....Huntsville District
I. C. Moore.....Madisonville District
Ethel Doan.....Navasota District
Jeanette Sangster.....Navasota Division

PORT ARTHUR DIVISION

Wanda Hubbard.....Lakeside Plant
Elizabeth Whatley.....Nederland & Port Neches
Madge Gonsoulin.....Port Arthur Division
Lorraine Dunham.....Port Arthur T & D

PHOTOGRAPHERS

Joe DeJean.....Baton Rouge
Jack Burhoe.....Beaumont
Charles DeCuir.....Port Arthur
Lloyd Clements.....Lake Charles
Pat Griffith.....Navasota

IN THIS ISSUE

PRESIDENT'S CHRISTMAS MESSAGE	1
MAKE IT A REDDY KILOWATT CHRISTMAS	2
CHRISTMAS CUSTOMS	3
GULF STATES SELLS \$10,000,000 IN BONDS	4
1949'S MOST POPULAR RECIPES	5
HOLIDAY LIGHTING	6
SAFETY SECTION	12

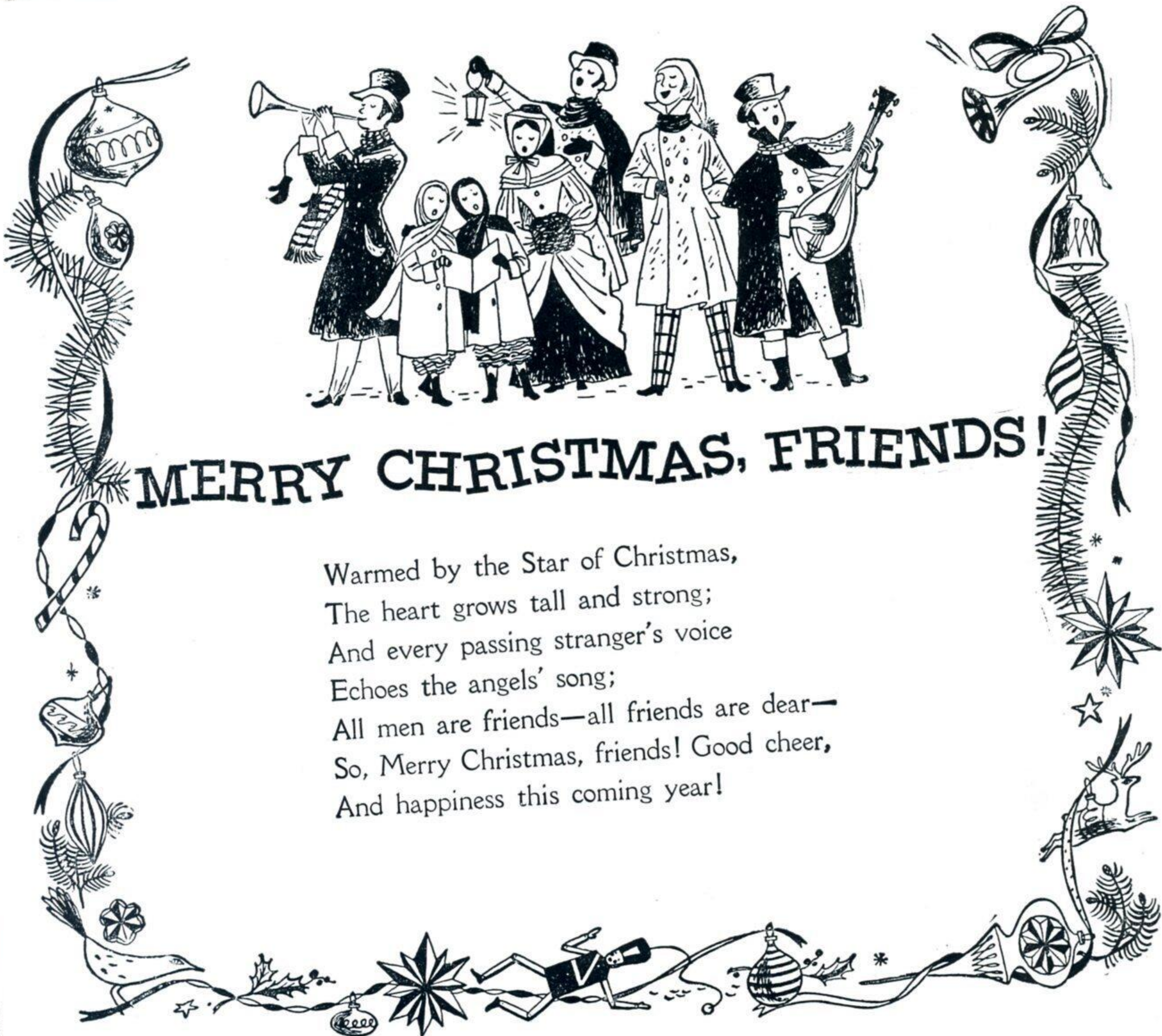

MERRY CHRISTMAS, FRIENDS!

Warmed by the Star of Christmas,
The heart grows tall and strong;
And every passing stranger's voice
Echoes the angels' song;
All men are friends—all friends are dear—
So, Merry Christmas, friends! Good cheer,
And happiness this coming year!

*MAY I echo, as a special greeting to all Gulf Staters and their families,
the words of this friendly poem.*

Roy Nelson

MAKE IT A REDDY KILOWATT
Christmas
Electrical Gifts
 KEEP ON GIVING



CHOOSE A PRACTICAL PRESENT THAT HAS
 A FUTURE. GIVE BETTER — GIVE ELECTRICALLY

Have you got that Christmas gift for the family yet? Time is **really** running out but our little friend Reddy Kilowatt has a suggestion that will save time and make Christmas happier too. His idea—make it a Reddy Kilowatt Christmas and give an electrical gift—a gift that keeps on giving all through the year.

Gift giving time is one time when you're really in an enviable position. With your employee discount on appliances purchased at the company stores you can afford to give what might otherwise be an impossible gift.

To help you with your last minute shopping we've prepared a list of electric appliances that are guaranteed to please those who are hardest to please. And there's a gift to fit most every pocket-book—so if you can't afford a range, or a refrigerator don't give up, there's almost certain to be a gift you want to give—and can give—further down the list.

Large Gifts

RANGE—If it's a long lasting gift for the whole family to enjoy why not make it an electric range. There's a wide range of styles—and prices—ask about them. The range is sure to please mom, and the meals it cooks will please everyone.

REFRIGERATOR—A modern electric refrigerator pays for itself by protecting the food your family eats and reducing food spoilage to the minimum. The new "two-temp" models are really nice for large families or those that eat a lot of frozen foods or want a handy place to store frozen quantities of food for longer periods of time than is possible in the conventional refrigerator.

WATER HEATER—Maybe a little unusual to give as a Christmas gift—but plenty practical. Some of those new electric models are beauties, too. They make an addition to any kitchen that's both practical and pretty.

Small Gifts

AUTOMATIC COFFEE MAKERS—If you can afford the coffee to put in them, the prices on these won't phase you at all. Perfect coffee every time—no watching—just put in the ingredients, turn it on and forget about it until you're ready to drink.

MIXERS—For a homemaker this is "the" gift. It saves endless hours cranking an old hand beater—or mixing things with a spoon. Once she uses one of these new electric mixers you won't be able to keep her from "whipping up" all kinds of goodies for you and the family.

ROASTERS—The name is a little misleading and often discourages folks before they look at them. A roaster will cook a whole meal and can be used just like an oven to bake or roast. They're especially nice in the summer when a whole meal can be prepared with little or no effort—or heat in the kitchen. Look at them—you'll like what you see.

HEAT LAMPS—Penetrating infra red heat rays are wonderful for tired or aching muscles, and to relieve the congestion of head or chest colds. It's also good for unclogging drains, drying paint—including the ladies' nail polish—drying the glue on a quick furniture repair job, or warming the baby's bed.

SUN LAMPS—Look better—feel better all year around. Every member of the family will appreciate the benefits of a sun lamp. For just plain healthy looking it can't be beat—and for a winter source of vitamin D there's nothing pleasanter. Look them over and pick one up for a healthier winter and a handsome "vacation look" all winter long.

HAND IRONS—Of course there's always the chance she may mistake your motive—or it may make a handy weapon for her sometime—but once she uses it (for ironing, that is) she's sure to like it. The new ones are light and automatic. Get her one.

VACUUM CLEANERS—The modern cleaners do a lot more than just clean rugs. With the attachments you can clean furniture, dust walls and venetian blinds, clean between radiator sections and do a real cleaning job on the family car, too.

(Turn to page 8)

**EMPLOYEES
 SPECIAL**

**WESTINGHOUSE ELECTRIC
 COMFORTER**

List price\$49.85
 Special Net Price.....\$28.50

**WESTINGHOUSE ELECTRIC
 SHEET**

List price\$24.95
 Special\$15.00

Employee price, of course, will be the Special Net Price plus 5%, plus transportation charges.

The legends behind our

Christmas

customs



WE all know, of course, what Christmas is and why. It is an event that has been set apart as a very special occasion for almost two thousand years. But, have you ever stopped to think about the many entirely different things we do at Christmas time merely because it's the custom—a custom of which usually we know nothing at all. Have you ever wondered why we do these things? There's kissing under the mistletoe for example, or singing carols, ringing bells, sending greeting cards, lighting the yule log and Santa Claus.

Ye Plain Talks editor has done a little research on this subject and has discovered some very interesting things. For instance, there's the mistletoe:

MISTLETOE

This is an outgrowth of an age-old custom found in the folklore of the ancient Germans and British Druids. In olden times mistletoe was so rare that it was considered sacred. If two people met under a sprig of this green in the forest, they became friends. Even enemies in battle, if they should chance to meet under the mistletoe, would put aside their arms and declare a truce until the next day.

One myth has it that the mistletoe bore the Garden of Eden's forbidden fruit, and that the holy cross was made from its wood.

Today a kiss may be claimed from anyone caught under a sprig of mistletoe.

CHRISTMAS STOCKINGS

This custom is founded on the legend that St. Nicholas dropped a purse down the chimney of an improverished home one Christmas eve and the money accidentally fell into a stocking on the floor. Since then they have been hung around the mantle or near the hearth or chimney of a fireplace so that St. Nick could find them when bestowing gifts and fill them easily.

SANTA CLAUS

Santa Claus as we know him is an American contribution to the legend of Christmas. The name is derived from Saint Nicholas—Santa from Saint and Claus for the 'cholas' sound in Nicholas—who was actually supposed to have been an archbishop during ancient times. In Europe he was a thin fellow, becoming his jolly fat self after crossing the ocean.

THE YULE LOG

The Yule Log is one of the older symbols of Christmas. For centuries it has stood for warmth, light and protection. In olden times the bringing in and lighting of the yule log was a special event on Christmas eve. It was always a huge piece of wood decked with flowers and ribbon. It was the custom to sit upon the log, sing a carol and kiss the log for good luck. Then the wood was lighted with a piece saved from the charred log of the previous year. If the new one burned, the year was held to be full of promise.

BAYBERRY CANDLES

Christmas isn't complete in many homes unless a bayberry candle is burned. The candle has been the symbol of enlightenment and an expression of Christmas joy for centuries. Bayberry wax is brittle and a translucent green and when the flame is extinguished, a perfume as sweet as incense pervades the room.

THE CHRISTMAS TREE

One legend has it that a tree with burning candles and the vision of a baby on its top was seen by a knight. This strange sight was interpreted to represent the Saviour, mankind (the tree) and human beings (candles). For centuries the tree, embellished in many fashions, has been the main decorative piece at Christmas time, both indoors and out. In the twentieth century many cities in America have sponsored public outdoor trees during the holiday season.

CHRISTMAS BELLS

Important happenings have for many centuries been heralded by the pealing of bells. So it is and has been since the beginning customary to welcome the birth of Christ with a joyous clanging of bells. Because in many places real bells are not available, the paper and papier-mache ones we see as decorations are used as symbols. There are a number of legends concerning bells, all very interesting, but space will not permit reciting them here.

CHRISTMAS CARDS

Christmas cards, messages of cheer and good will today, have their origin in class room assignments in English schools. Each year at Christmas time, pupils turned in specimens of their handwriting on large sheets of paper to demonstrate progress in penmanship during the year. These were called "Christmas pieces," and were decorated with elaborate scrolls and flourishes. In time they grew more fancy and were colored; and from them evolved our Christmas cards.

SINGING CAROLS

The singing of Christmas carols was begun in England when the bishops caroled on the eve of the holiday. Later the custom was taken up by the people. Therefore today we herald Christmas with songs.

GIFTS

This custom began back in the ancient days of Rome. Boughs of sacred laurel, olive or myrtle were given to the king around this season to protect him through the coming year. The custom became more general and later gifts of sweets were added. In time more practical gifts replaced the sweets.

And there you have it. Isn't Christmas wonderful?

More about Money

GULF STATES SELLS \$10,000,000 IN BONDS AT PREMIUM RATES

Another step in financing our expansion program was completed within the past month with the issue and sale of \$10,000,000 of first mortgage 30-year bonds by the company.

Low bidders were a group of underwriters headed by Stone & Webster Securities Corporation. This group bid a price of 102.1499 on a 2¾% coupon bond. This means that for each of the ten thousand \$1000 bonds, the company received approximately \$1,021.50, and will pay interest on each of such bonds in the amount of \$27.50 annually. A breakdown of these figures shows that on this one bond issue alone the company will have an annual interest payment of \$275,000 or over \$750 every day (including Saturdays and Sundays). The company will use the proceeds from these bonds to pay off outstanding short-term bank notes and for additional construction.

The new bonds were offered to the public at a price of 102.58, to yield 2.65% to maturity in 1979.

Usually leading investment and brokerage firms form into groups to handle a bond issue as large as \$10,000,000. Each group submits a bid which sets forth how much it will pay Gulf States for bonds of a stated coupon rate.

RATE INDICATES CONFIDENCE IN G.S.U.

President Roy Nelson pointed out that the favorable price received for the issue, plus the other bids made, is indicative of the confidence which investors have in the future of the company and of the 27,500 square mile area which it serves along the Gulf Coast.

With the sale of this latest issue completed, a summary of the new capital raised through permanent financing to obtain the money needed for the company's expansion program reveals that already a total of \$55,910,650 has been raised. The amounts and manner of this financing are listed as follows:

SUMMARY OF FINANCING

\$5,000,000 received from the sale of a new series of preferred stock in December 1947.

\$3,410,650 received from the sale of 272,852 shares of common stock in December 1947 and January 1948.

\$12,000,000 received from the sale in April 1948 of first mortgage bonds, 3% series due 1978.

\$4,500,000 received from the sale of 278,479 shares of common stock in January 1949.

\$15,000,000 received from the sale, also in January 1949, of 3% debentures due January 1, 1969.

\$6,000,000 received from the sale in October 1949 of 60,000 shares of a new series of preferred stock.

\$10,000,000 received from the sale in December 1949 of first mortgage bonds, 2¾% series due 1979.

Actual expenditures on the expansion program for the years 1947, 1948 and 1949 will total \$64,600,000. The difference between this figure and the total raised through permanent financing was made up principally from the company's annual provision for depreciation and from earnings, retained in the business instead of being paid out in dividends to stockholders. In 1948 for example, the provision for depreciation amounted to more than \$2,300,000. In other words, for every dollar Gulf States received from its customers, about ten cents was set aside to provide for the replacement of worn out plants and facilities, and for each year of the expansion program this money was used to help finance new construction.

Retired Gulf Stater Dies at Beaumont

Samuel Benjamin Scott, 82, retired veteran Gulf Stater of Beaumont, died November 13 following an injury suffered several weeks prior to his death. Mr. Scott broke his hip in a fall at his home and developed pneumonia following the accident.



A native of Florence, Alabama, Mr. Scott had made his home in Beaumont for the last 48 years. Well known around Beaumont he was keenly interested in the affairs of the community and of the welfare and activities of his many friends before he was confined pretty much to his home because of his advanced age. One of the big events in Mr. Scott's life in his later years were the annual Gulf States Service Award dinners which he never failed to attend. He was one of the oldest, and a very active member of the First Christian Church up until his accident.

Mr. Scott began work with the old Eastern Texas Electric Company in 1903, working in the street car repair department most of the time. He was transferred to Gulf States in 1932 when Eastern Texas went into the hands of receivers and since that time and until his retirement three years ago he served the company in various capacities. He was employed in the substation department when he left.

Surviving Mr. Scott are a son, E. R. Scott; one daughter, Mrs. John Drinkard of Beaumont; four grandchildren and three great-grandchildren. On behalf of Gulf Staters, Plain Talks extends sympathy to these survivors.

Fishermen Three ...

FISH — Fish — and more fish. These Gulf Staters had 'em—277 pounds of them. The proud fishermen, who refuse to divulge the location of "the hole" are, left to right, C. W. Dobberine, Murphy Gibbs and Freddie Faulk, all of Lake Charles. They did say they used the same bait Beaumont Sherman West uses, but the closest they would come to telling where was somewhere south of Lake Charles. Fine pals! The catch included 20 Reds, 35 Specs, 4 Sheep Head, and 8 Flounder.



1949'S MOST POPULAR GULF STATES' RECIPES

During the year 1949 you have probably seen several recipes in this column that were particularly good, one that your family and possibly your friends complimented you on as being unusually tasty and attractive. If you make it a point to get the monthly recipe bulletin, "How To Make", put out by the home service department you no doubt found many other such recipes. Each one of these recipes is tested by one of our home service advisors, and are approved by them, and while all will not please everyone there is a variety from which quite a number of people should get suggestions and help. Which brings us up to now.

From the twelve "How To Make's" published during the past year our home service director, Leonora O'Neal, has selected the recipes listed in this issue of Plain Talks as the most popular, based on the number of comments from those using the recipes and requests for them from others. Most are on the "sweet tooth" side but there is a variety you might like to clip and put with your favorite recipes as they will surely become once you've tried them. Here are 1949's Most Popular Recipes:

FROZEN CHERRY SALAD

- | | |
|-------------------------------|-------------------------|
| 2 cups fresh cherries, pitted | 1/3 cup pecans, chopped |
| 1/2 cup pineapple, diced | 1/2 cup mayonnaise |
| 1/3 cup bananas, sliced | 1/2 cup cream cheese |
| | 1/8 tsp. salt |

Combine cherries and pineapple, bananas and pecans. Blend together the mayonnaise and cream cheese. Add salt. Combine with cherry mixture. Mix thoroughly and pack in refrigerator tray and freeze. Cut into squares and serve on crisp lettuce leaf. Serve with ribbon sandwiches.

SHRIMP COCKTAIL SAUCE

- | | |
|------------------------------|--------------------------|
| 1 cup mayonnaise | 2 Tbsps. celery, chopped |
| 1/2 cup chili sauce | 2 Tbsps. onion, grated |
| 2 tps. Worcester-shire sauce | Juice of 2 lemons |
| 1 tsp. hot sauce | Salt and pepper |
| 4 tps. horseradish | 1 small clove garlic |

Mix all ingredients in order given. Chili. Remove garlic before serving over chilled shrimp: Wash and cook in boiling water seasoned with "Seafood Boil" for 20 minutes. Peel shrimp and remove black vein (Chill.)

BROILED HAM WITH FRESH PINEAPPLE

- | | |
|----------------------------|---------------------|
| 1 cup diced pineapple | 1/4 cup brown sugar |
| 2 1-inch slices smoked ham | Cloves |

Remove ham from freezer and let thaw 2 hours. If placed in broiler before thawing allow 15 minutes (8 minutes on first side and 7 minutes when turned) longer for cooking. Place meat on broiler rack about 4 inches from broiler unit. Broil first side 10 minutes. Turn, stick cloves in meat and top with frozen diced pineapple. Sprinkle with brown sugar. Return to broiler for ten minutes. This gives the pineapple time to thaw. If canned pineapple is used, allow only 8 minutes for broiling after turning.

PINEAPPLE CHIFFON CAKE

- | | |
|-------------------------------|-------------------------------------|
| 2 1/4 cups cake flour, sifted | 5 unbeaten egg yolks |
| 1 1/2 cups sugar | 3/4 cup unsweetened pineapple juice |
| 1 tsp. salt | 1 cup egg whites |
| 3 tps. baking powder | 1/2 tsp. cream of tartar |
| 1/2 cup salad oil | |

Sift dry ingredients into mixing bowl; make a well in dry ingredients. Add salad oil, egg yolks and pineapple juice in order given. Beat until satin smooth. Combine egg whites and cream of tartar in large mixing bowl. Beat until they form very stiff peaks (stiffer than for meringue or angel cake). Fold egg yolk batter gradually into egg whites. Bake in ungreased 10-inch tube pan in an electric oven at 325 degrees for 55 minutes, then at 350 degrees for 10 minutes. Invert to cool. Frost with Pineapple Parfait Frosting.

JIFFIES

- | | |
|---|--------------------------------|
| 13 graham crackers (broken pieces not crumbs) | 1 can sweetened condensed milk |
| | 1 pkg. chocolate bits |
| | 1/2 cup chopped pecans |

Combine graham crackers, condensed milk, chocolate bits and nuts. Mix together thoroughly and pour into greased 8 inch square pan. Bake electrically at 350 degrees 30-35 minutes. Cut in squares while still warm and remove from pan. They may appear not to be cooked but are a chewy cookie and set when cool.

PECAN PRALINES

- | | |
|---------------------------|---------------------------------|
| 1 cup granulated sugar | 1/8 tsp. salt |
| 2 cups light brown sugar | 1 1/4 cups milk |
| firmly packed | 2 tps. maple flav-
ing |
| 3 Tbsps. white corn syrup | 1 1/2 cups unbroken pecan meats |

Combine the sugars, corn syrup, salt and milk in a saucepan. Cook gently, while stirring constantly until small



Cherie LaForest Joins Home Service

The most recent addition to the home service department is Cherie LaForest who joined the staff at Lake Charles on October 10. Cherie fills a vacancy created when Ruth Hession resigned from the company after serving on the Lake Charles staff for twenty-four years.

Cherie, who is a native of New Orleans, is well qualified for her work. She has received all of her education in Louisiana schools, graduating this year from S.L.I. with a B.S. degree. She worked for the Ironrite Ironer Company for several months prior to joining Gulf States.



Helpful Household Hints . .

To save burned food, uncover cooking pan and set in a large pan of cold water until the steam escapes. Discard pieces of food stuck to the pan. The burned taste goes off with the steam.

To prevent the yolks of hard-cooked eggs from turning green—plunge the eggs into cold water immediately upon removing them from stove.

A good salad dressing for the dieting person is to rub the salad bowl with a garlic clove, then sprinkle the lettuce leaves with lemon juice, add salt and pepper. Toss the salad and top with parsley flakes.

To prevent soggy pie crusts, cool cream and custard fillings before pouring into shell. For fruit pies, crush and sprinkle a layer of corn flakes over the bottom of crust to prevent the berry juice from seeping in.

Next time you want to clear soup of excess fat, try putting lettuce leaves in it—the fat adheres to the lettuce.

amount of mixture dropped in cold water forms a soft ball, (236 degrees F.) Remove from heat and cool to lukewarm (110 degrees F.) Stir in maple flavoring and pecans. Beat the praline mixture until it begins to thicken. Drop quickly from a spoon onto waxed paper to form patties about 4 inches in diameter. When firm, wrap in waxed paper. Yield: 12 2-oz. pralines.

Spread Yuletide Cheer with HOLIDAY LIGHTING

GAILY COLORED LIGHTS HELP YOU WISH THE WORLD
A MERRY CHRISTMAS AND HAPPY NEW YEAR

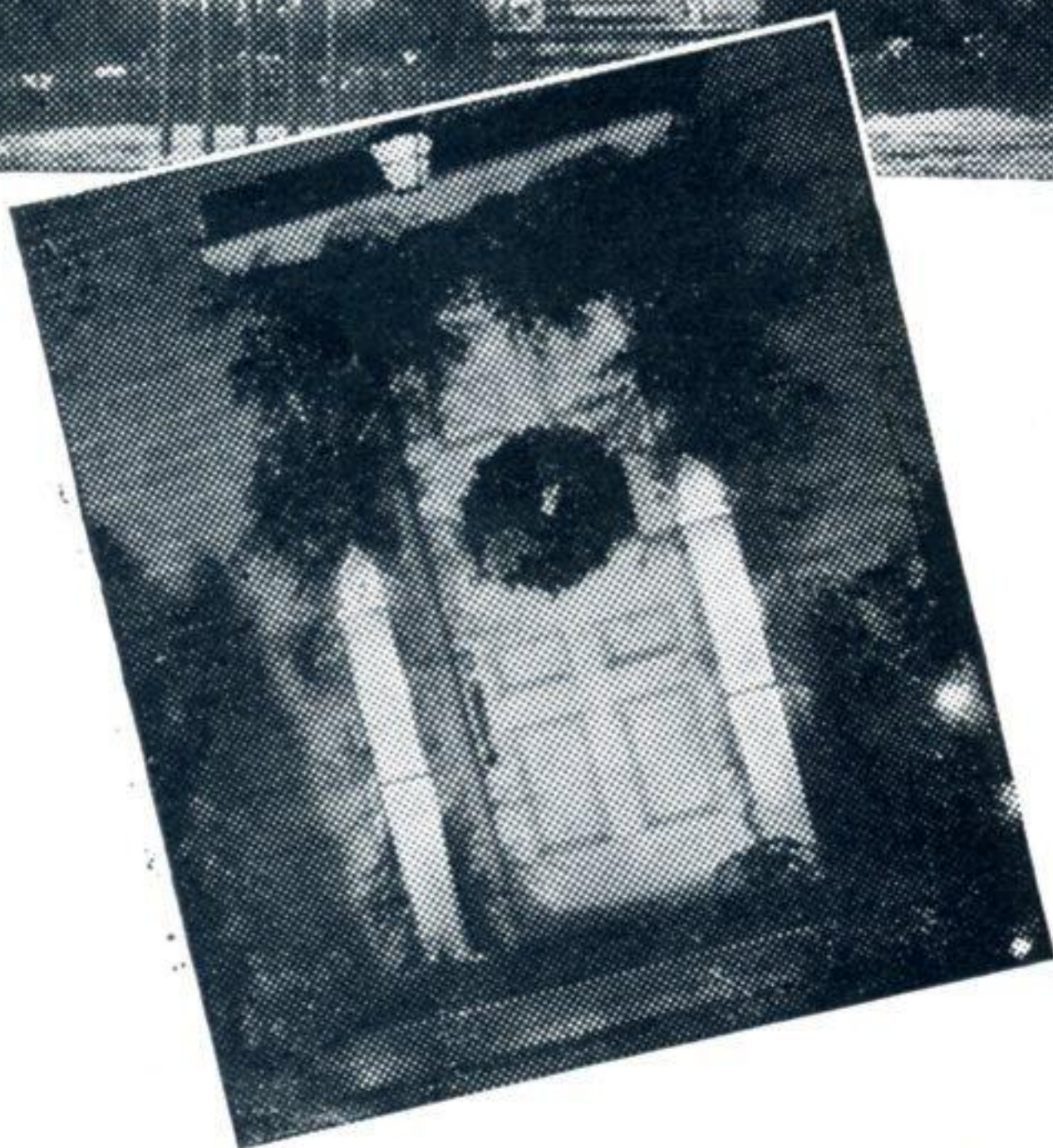
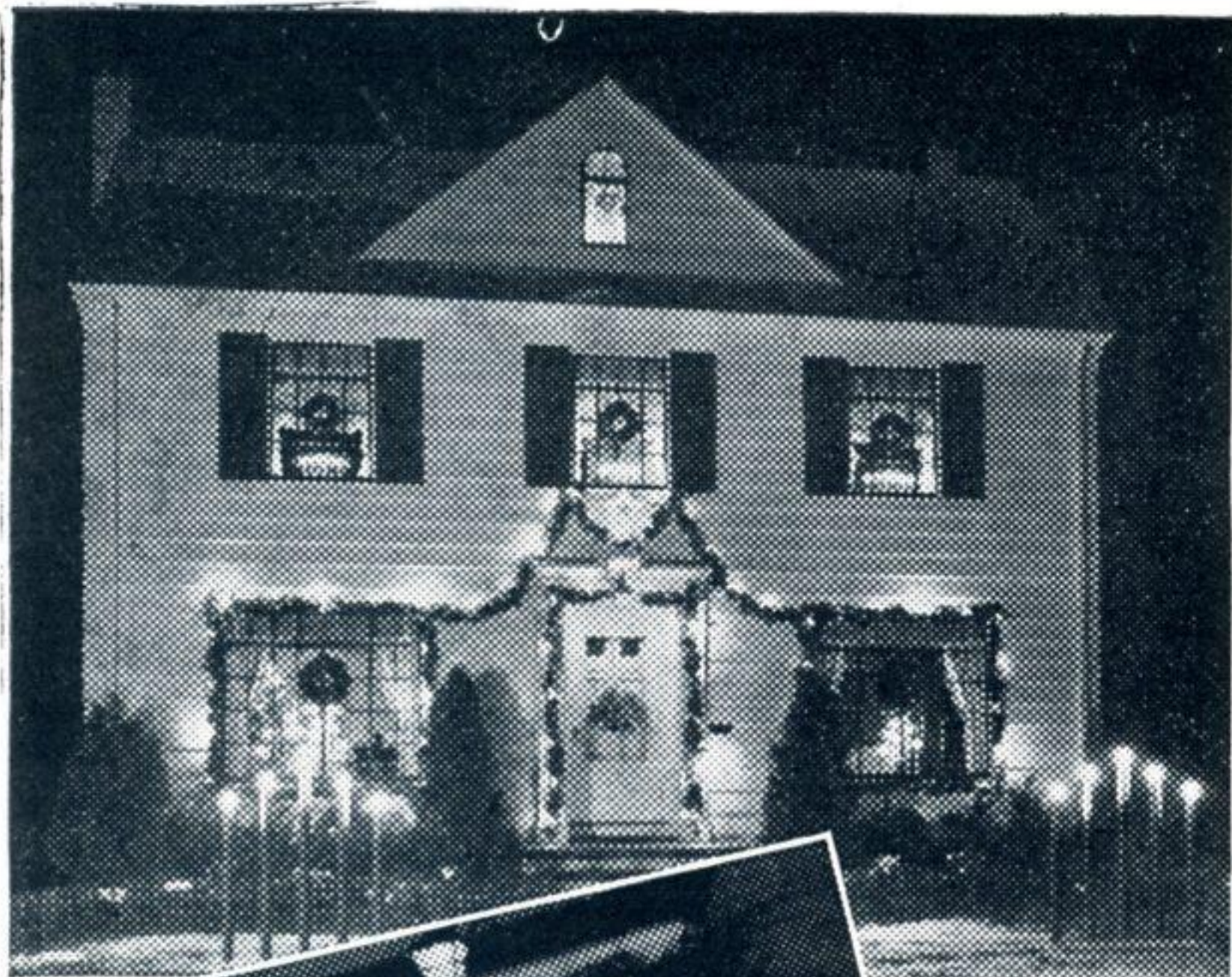

A little work and a little ingenuity will turn your home into a lighted greeting card.

strings of colored bulbs, fastened to the house in the shape of a pine tree.

For a touch of fantasy that appeals to adults as well as children, why not have a snowman family on your front lawn. The charming trio pictured in the upper right-hand photograph are simply cutouts of construction board, painted white to resemble snowmen. All three are lit by an outdoor Projector Floodlight (which has a built in reflector) concealed in a near-by bit of shrubbery.

DECORATE DOORWAYS

No matter how simple or how elaborate your outdoor decorations, plan to give special emphasis to your front entrance. Light helps extend your holiday hospitality, so use it with a lavish hand.

The generously bedecked holiday doorway pictured at the lower left above bids welcome to each guest who enters. Tall plywood candles (lighted from behind with rows of colored lamps) light not only the doorway but the handsome holly wreath and the overhanging evergreens.

Bells and boughs, accented with a different type of glowing illuminated candle, create an attractive setting for a recessed doorway. As pictured in the left picture in the layout at the right bottom of the page, colored bulbs are used in the three fireproof papier-mache bells above the door.

W E Americans are known throughout the world for our generous, happy spirit, our willingness to share with others the many blessings that we enjoy. As the Christmas season approaches it seems that this important virtue grows and grows, and utter strangers with whom we come in contact are made happier because of this wonderful characteristic. It has become an American tradition.

Your home, too, can express this same personality, your joy and happiness this Christmas season—with holiday decorations. Decorations need not be expensive nor need they be elaborate to be effective. Electric lights can accomplish most of the decorating any home needs to be

festive, hospitable and also extend a colorful greeting to all who see it.

Here are but a few of the decorations that you will enjoy creating for your own home.

If your house has graceful lines, try festooning the front with evergreen rope and colored outdoor lights as shown in the upper left-hand photograph. Holly wreaths in each window are accented with light from electric candles which may be purchased ready to use.

Another interesting treatment is to frame a front window with a giant outline of a Christmas tree. As shown in the photograph at the lower-right above, the outline tree is made of laurel rope and

Strings of colored outdoor bulbs are also nestled in the evergreen boughs along the eaves. The twin candles are products of a home workshop. Although the candles shown here are made of painted composition board with flames of translucent material such as plastic, cellophane or spun glass, you can make similar ones quickly with a piece of pipe, a sturdy can or crock for a holder and a single outdoor socket with a colored bulb for a flame.

The simple dignity of the doorway at the right in the same layout below is achieved by placing a projector floodlight in a swivel-type holder and positioning it so that it is aimed at the handsome wreath of Christmas greens on the door.

Another simple yet effective lighted doorway shown at the lower right in this layout uses strings of colored outdoor Christmas lights and long needle pine boughs. Three glistening silver bells with musical clappers proclaim the gold-lettered message JOY as the door is opened for guests.

In the illustration at the lower center are several of the possible ways to mount adjustable weather-proof lampholders, for outdoor lighting (always use two-conductor outdoor rubber cord, with weather-proof plugs if extensions are to be used).

INDOOR DECORATIONS

The interior of a home can be brightened in many, many ways to give that holiday atmosphere. The main decorative effect is, of course, obtained from the old standby the Christmas tree. However, to supplement this piece there are any number of ideas that can give a pleasing touch to other rooms in the house.

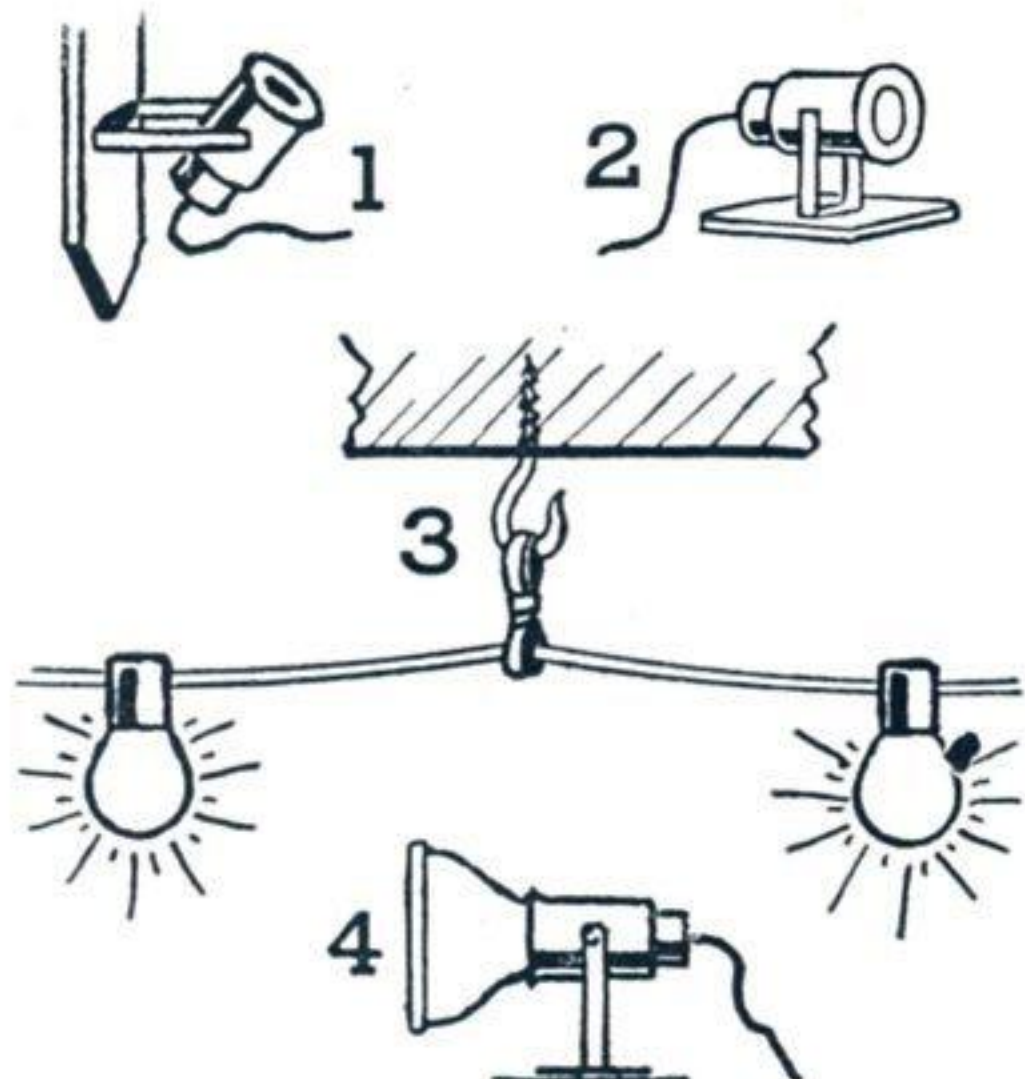

Bulbholder mounted on board peg (1); holder mounted on base of scrap board (2); a projector lamp in a standard outdoor holder is shown in drawing No. 4. Wire screw eyes or hooks, as shown in drawing No. 3, may be used for convenience when festooning evergreen. Tape wires at hook for safety and place hooks close together to prevent lamps from striking the wall.

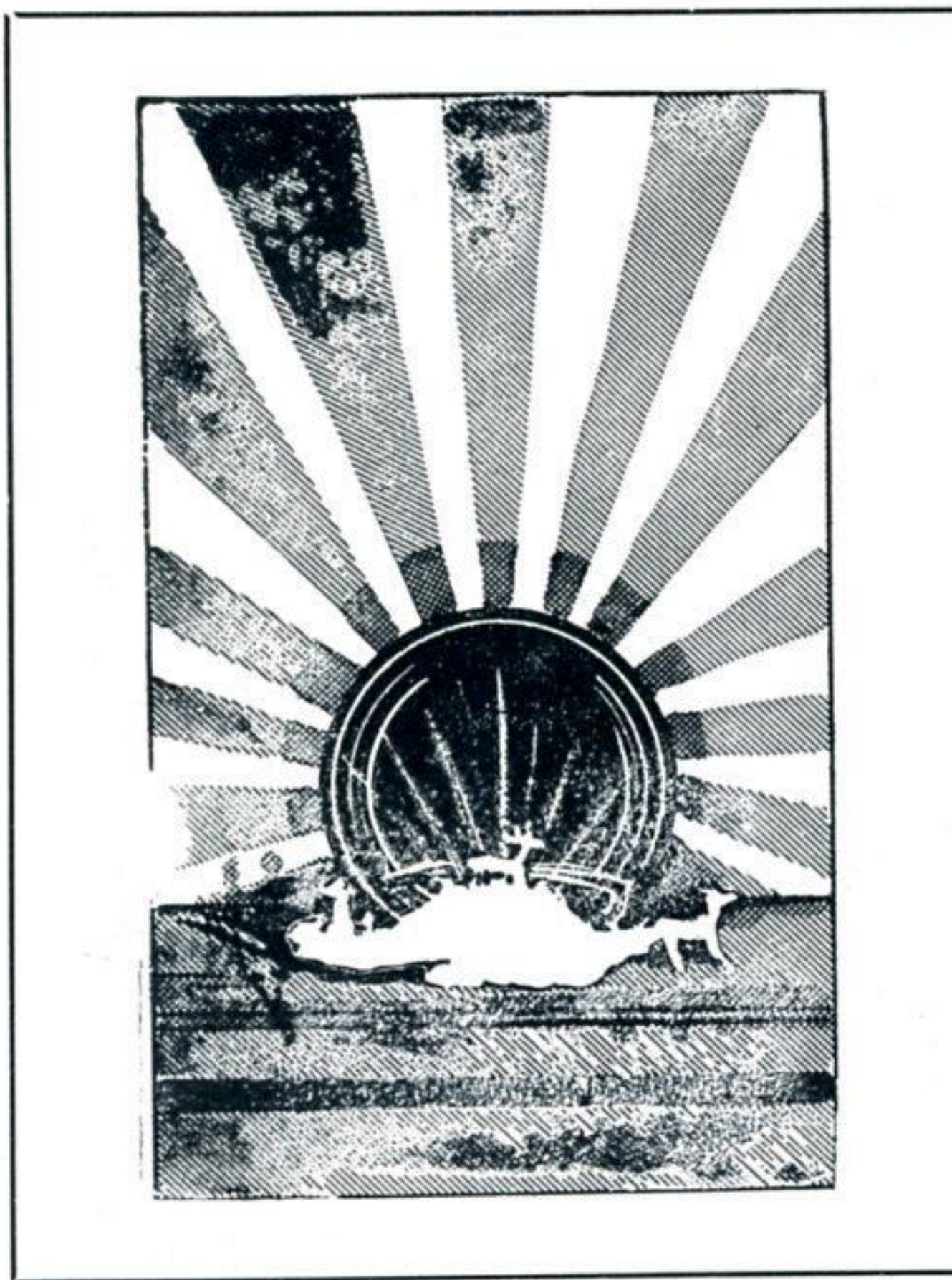

Highlight the arrangement by placing it in front of a small circular mirror on a mantel or shiny silver tray to catch the light. Turn the slits toward the wall so that it reflects the sunburst effect.

Bouquets of greens on mantel, table, sideboard or desk top can be enhanced by placing a string of warm-colored Christmas tree bulbs at the back to cast graceful shadows on the wall. Branches and bulbs should be carefully arranged so that the best shadow effects are achieved. A variation of this would be to add lighted stars and bells to the branches if the wall does not lend itself to the decorative shadow arrangement.

Snow scenes with miniature figures are also a delightful touch for your indoor decorations. Border the scene with a string of tree bulbs and add spun glass or artificial snow. Tiny trees and figures can be purchased inexpensively and arranged in many different ways.

A more formal yet colorful table piece may be achieved with a string of colored bulbs in a bowl or on a table mirror. Cover the lamps with Christmas tree balls of varied size and color. Encircle the arrangement with sprays of holly or pine.

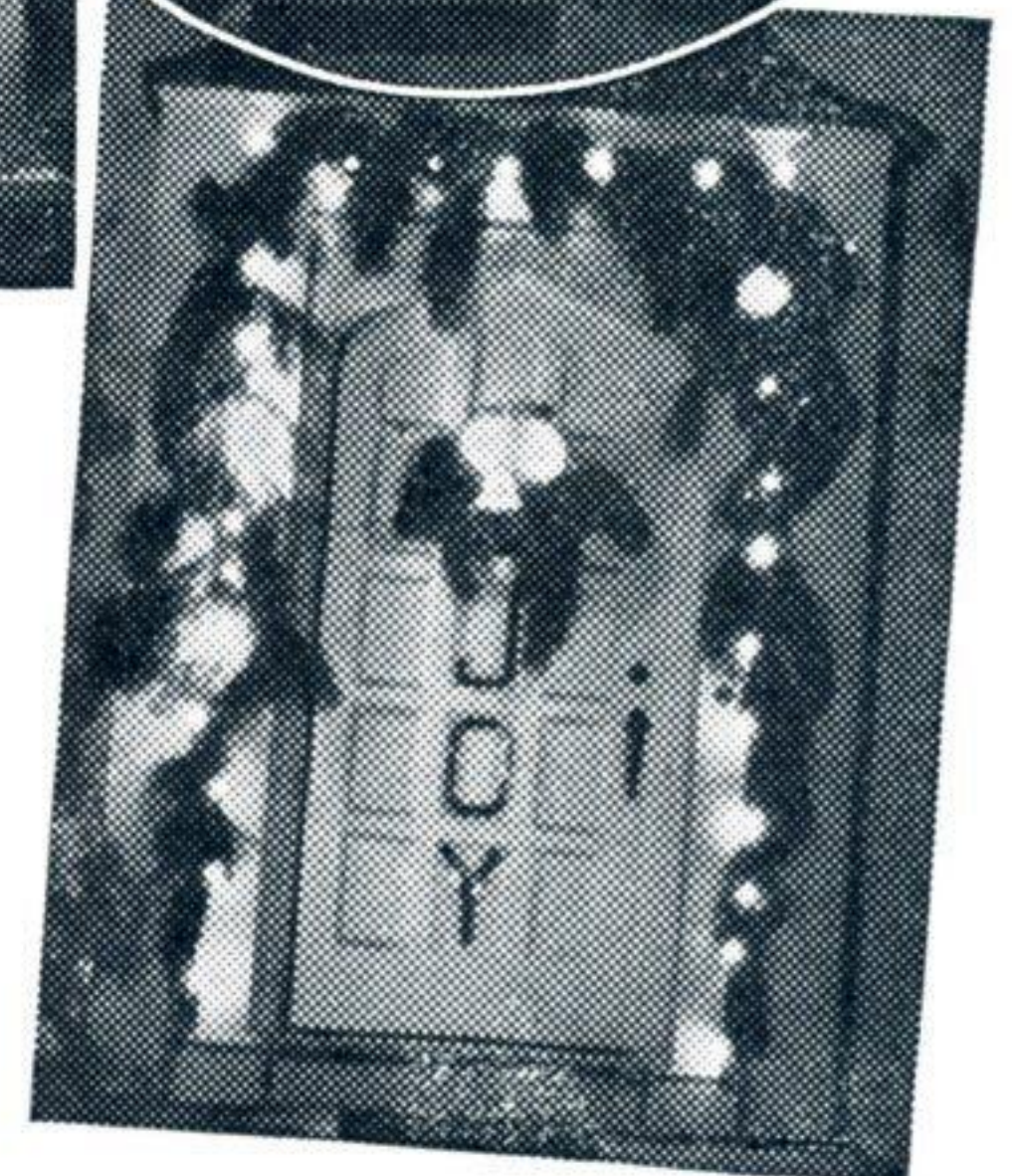
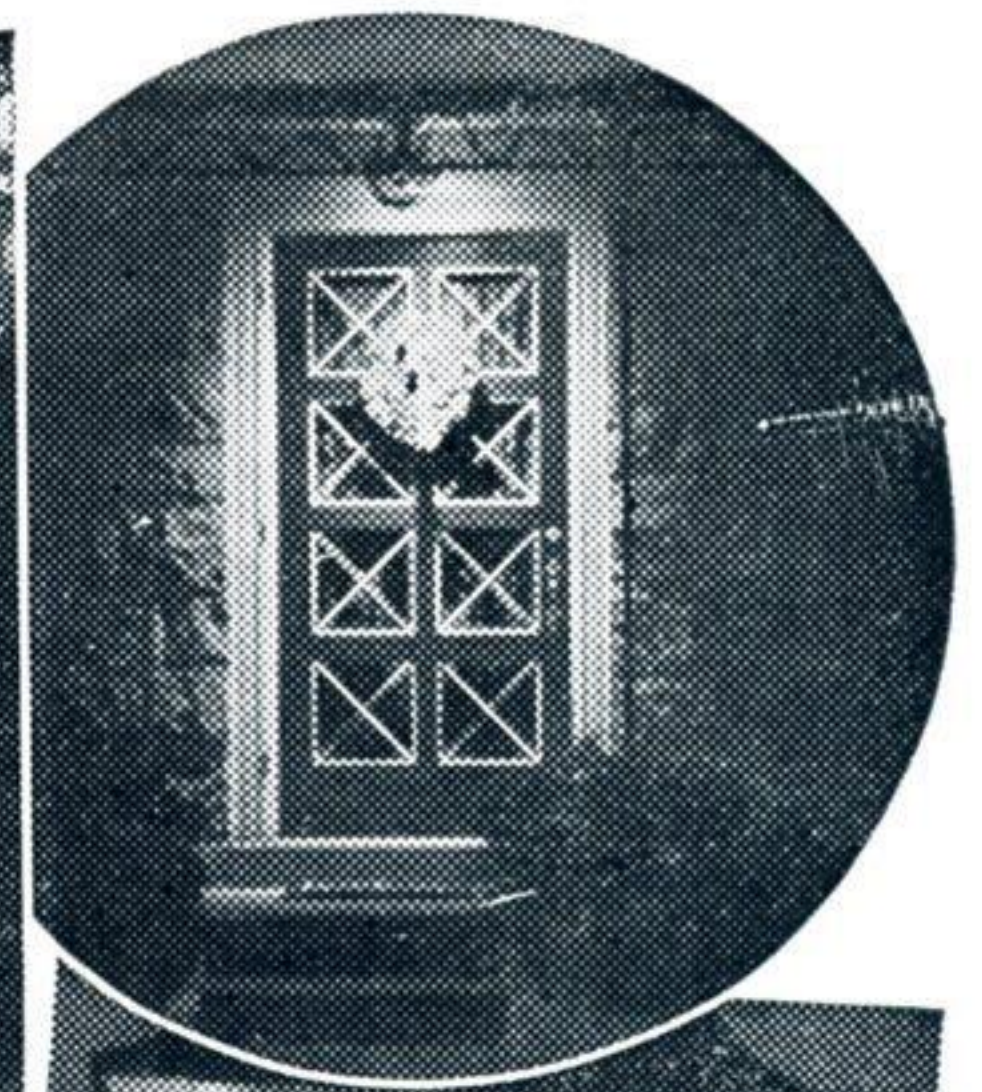
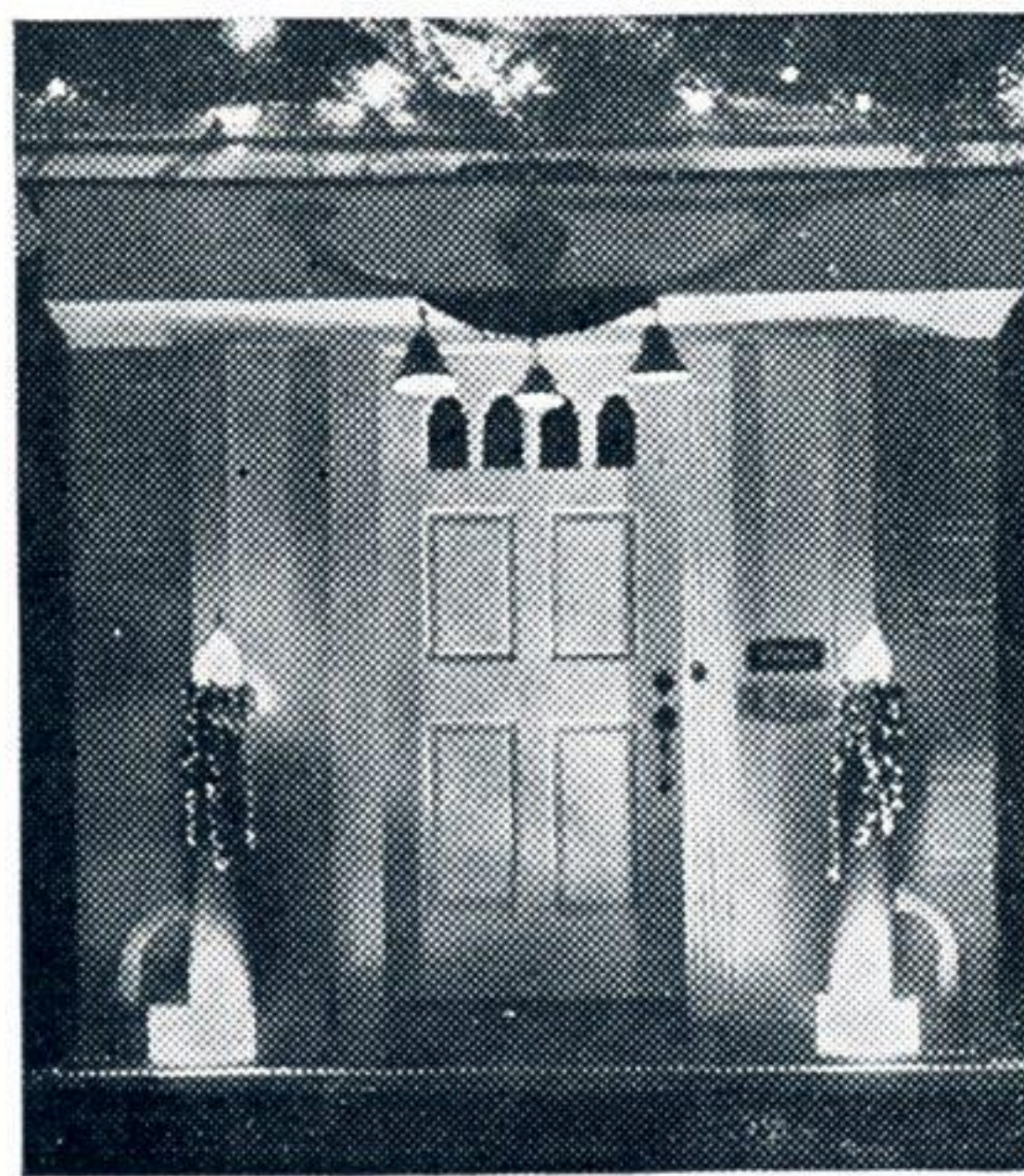

SANTA VISITS G.S.U. KIDS AGAIN



Every year about this time the company's little folks suddenly find themselves the center of attraction as Santa visits the annual Christmas parties held throughout the system. Fun and frolic

are the order of the day—with the older folks getting just as big a kick out of the show as the most enthusiastic children.

This is the third year for the "Tiny Tot" parties, and everyone agrees that they're lots of fun. In the larger towns and cities there are several parties, each department, or a couple of departments, sponsoring one. In the smaller towns there is usually one big affair with all departments participating and attending. An idea of how popular they are is reflected by Beaumont's parties last year which attracted approximately a thousand guests. This year about the same number are expected.

All of the parties follow the same fun lovin' pattern with refreshments, entertainment—and of course, the main event when Mr. Claus distributes the gifts to the kids. If you and your family haven't been to one of these parties make it a point to attend the next one your department or office sponsors, they're loads of fun and a good opportunity to get acquainted with your Gulf States neighbors.

New Employees

On behalf of all Gulf States, Plain Talks extends a hearty welcome to these new employees. If any of these people are in your building, town or neighborhood, look them up and get acquainted. They are:

BEAUMONT—Mary W. Bobbitt, Robert A. Werner, Mary Carter, Elra A. McLendon, Bernadine Rougeau, Donald O. Nelson, C. R. Griffith, accounting; James W. Ryan, Robert J. Summers, Jack A. Hawkins, John T. Hayes, Ethan R. Van Meter, Gerald O. Dean, t & d; Hazel K. Nesmith, engineering.

PORT ARTHUR—Richard Andrew Landry, Jr., lighting; W. J. Gobert, Dempsey Rowzee, Norman Dow, t & d; Stanley C. Brown, accounting.

NAVASOTA—A. J. Griffith, J. C. McClendon, John E. Hughes, Douglas C. Parker, Leal Hall, Jr., Louis Caldwell, Jr., t & d.

LAKE CHARLES—Cherio Marie LaForest, home service; Peter LeBlanc, Wallace Gradnigo, Pauline Selby, J. V. Tripeaux, Doris Amy Smith, Melvin Manuel, t & d; George E. Bourgeois, Wendall R. Gammage, production; Alyene Coker O'Neal, customer clerk.

BATON ROUGE—Gladys Mae Akin, Vernon Charles Young, t & d; Emery Joseph, George Emery, Zelma K. Sargent, Joseph R. Bonaventure, gas; Edward D. Vallet, Harvey Smith, Jr., Allen James Colomb, Guy Robert Reid, Jr., Joachim Sylvest Himel, Charles E. Harris, Johnnie L. Young, LeRoy Wheat, Jr., Joseph F. Hebert, Claude J. Greely, production; Jerry Fakin, customer clerk.

OTHERS—Eugene James Harmon, Camille Miller, t & d, Jennings; Jack H. Peck, t & d, Lafayette; Stanley C. Brown, accounting, Nederland; Ruth A. Clevenger, Orange, customer clerk; Malvin Wiggins, Liberty, t & d; Philip LeDoux, Sulphur, accounting.

Bill Callahan Retires

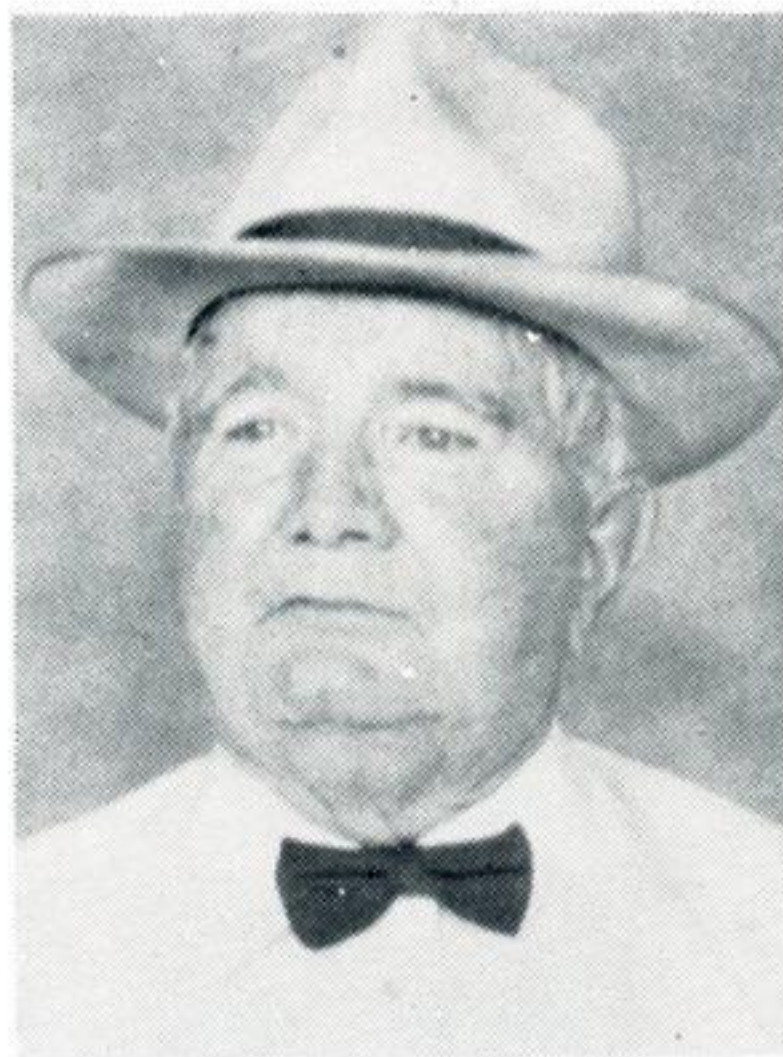

The employees of the Orange District and a few Neches Station employees had an informal "going away" party recently to honor William R. Callahan, veteran watch engineer in the Orange production department who retired from the company October 31. During the party he was presented with a handsome self winding "Mido" wrist watch and a triple X Stetson hat by his fellow employees.

The party was a friendly get together at the company bunkhouse at Orange, with all employees and their families invited. Many stories of the "good old days" were told and relived at the reunion of his friends, some who have been away from Orange on other jobs for many years. Soft drinks and hot coffee were served.

Mr. Callahan left the day after the party with his wife and son to spend a couple of months in California. He will return to Orange where he will continue to make his home.

Born in New Orleans, Bill Callahan went to school in Orange and continued to make that city his home. He went to work for the old Orange Ice, Light and Water Company in 1922, coming with Gulf States when the Orange property was purchased in 1925. Bill never desired to leave Orange and his entire career with the company was spent in that city.

ELECTRIC GIFTS KEEP ON GIVING

(Continued from page 2)

LAMPS—A sure fire pleaser everytime is a new lamp. There are models and styles available for every member of the family—and for every seeing task. Brighten up this Christmas with a lamp for your family.

WAFFLE BAKER—With one of the new waffle bakers you can even serve waffles when you have company and nobody has to wait for the next one to get done. Look them over—they make an ideal gift and they turn out perfect, golden brown waffles every time.

TOASTERS—A little appreciated item in most families is the toaster that serves up that delicious, perfectly done toast every morning. One reason probably is that the only time most of us see it is in the morning when we are in too much of a hurry to appreciate anything anyway. The time saving feature is another reason for getting one too. The newest toasters do everything except get the bread out of the bread box. They're fascinating—as well as practical.

ELECTRIC HEATERS—Is the bathroom chilly when you get up in the morning? Get a new electric heater and enjoy the difference. The whole family will appreciate the instant warmth and the cleanliness of electrical heat. A real family gift.

CLOCKS—Big clocks — little clocks: alarm clocks — chime clocks: kitchen clocks—mantle clocks: any kind of clock you can imagine, and they're all electrical. Look them over—you're sure to find the one you want—or want to give.

HEATING PADS—You don't have to be sick to enjoy the comfort of a heating pad—although that probably is the one outstanding occasion for its use. Many people warm the baby's bed with it before they tuck him in it. There will be many uses for it once you have it.

FOOT WARMERS—Cold feet is a common ailment during the winter months, and a sure cure—if you don't want to invest in a complete electric blanket—is an electric foot warmer. For warm feet it's electricity two to one.

CHRISTMAS TREE LIGHTS AND SPARE BULBS are available in company stores for outdoor and indoor use.



G.S.U. Extends Service to DeRidder

An extension of Gulf States' electric system was made early this month when a new 34,500 volt transmission line from Buhler to DeRidder, Louisiana was placed in operation. This new line was built to furnish power for the two electric systems serving DeRidder and the neighboring rural area in Beauregard and Calcasieu Parishes.

These two organizations, the Gulf Public Service Company and Beauregard Electric Cooperative, will now purchase power wholesale from Gulf States and continue to supply their customers through their own distribution systems. Gulf Public Service serves Leesville in addition to DeRidder and part of the power purchased from Gulf States will be carried over a Gulf Public transmission line to help serve that city. Gulf Public Service Co. and the cooperative formerly obtained electricity from the plant of the Long Bell Lumber Company at DeRidder.

The new line to DeRidder ties into the Gulf States transmission line which extends from Sulphur to DeQuincy. Thirty-nine miles in length, the line is of wood pole H-frame construction and is designed to meet all normal weather conditions in this area. Over 500 fifty-five foot poles were used in its construction, and approximately 120 miles of copper wire are used in the circuits through which the electrical energy is transmitted.

When load conditions require it, the line will be extended from Buhler directly to Riverside generating station at Lake Charles and will at that time be converted to 69,000 volt operation. The line was designed and constructed to carry this higher voltage and can be quickly converted to operate at 69,000 volts.

In addition to the transmission line, Gulf States has also built a new 3,000 kva substation near the Long Bell Lumber Company. Gulf Public Service and Beauregard Cooperative will tie in their facilities to our line near this point.

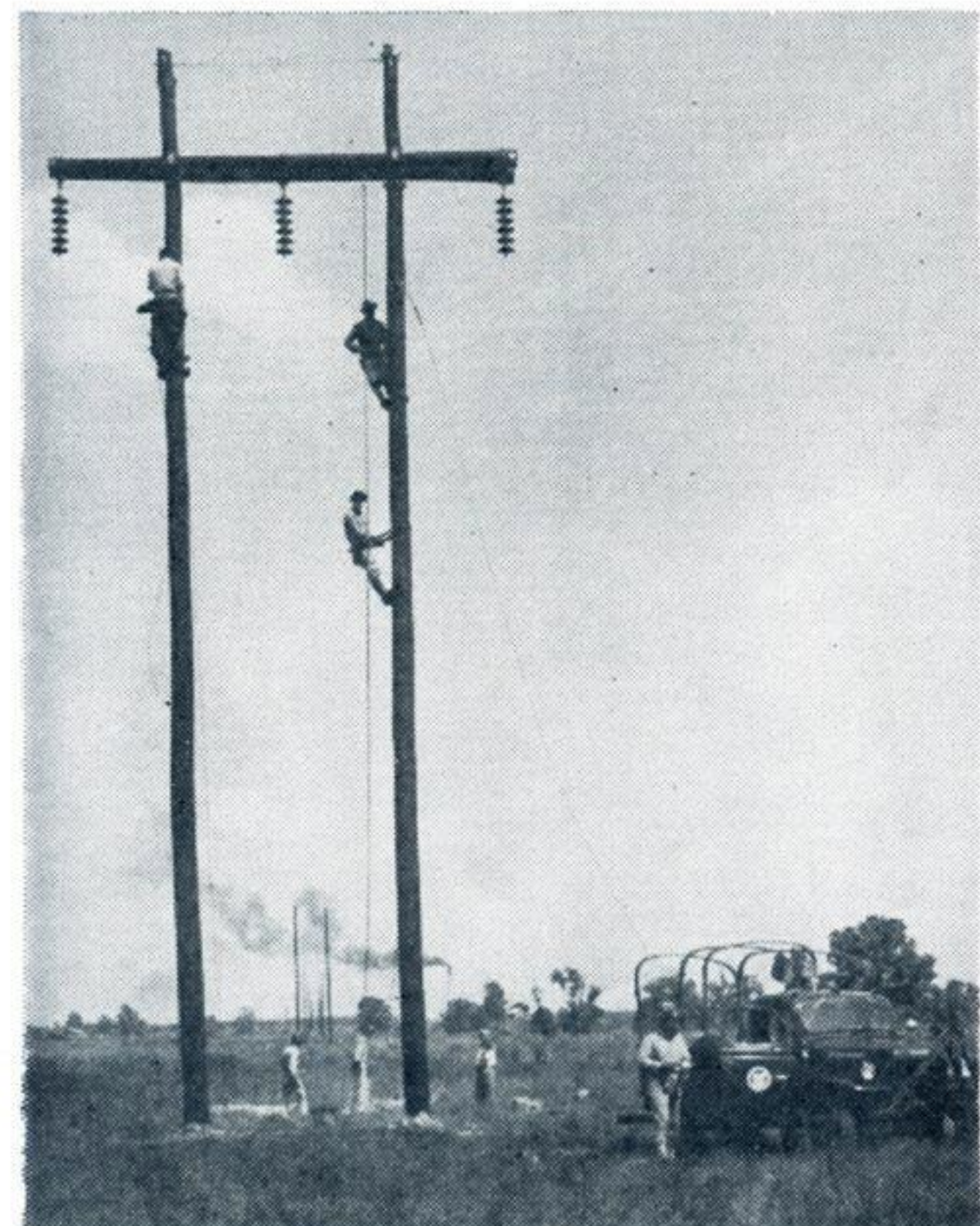

LAKE CHARLES Division Gulf Staters are shown here putting the finishing touches on the Buhler-DeRidder transmission line.

Plain Talks

Vidor Remodels Office Holds Opens House



VIDOR'S NEWEST BUSINESS OFFICE is shown in the top picture. Mrs. Ercell Smith, local customers clerk (behind the counter) and Bonnie Thompson, Beaumont sales representative, serving the young ladies, helped make the open house a big success. At bottom is shown half of the office and also the staff, who is T. H. (Snooks) Lindsey, Vidor serviceman. Standing next to Snooks is his wife. The other two women are friends who dropped in to see the new office.

The cause of much festivity in the little town of Vidor, Texas, recently was an open house held by the company to celebrate the opening of a new office there. Mrs. Ercell Smith, local customer's clerk, and "Snooks" Lindsay, Vidor serviceman, with the aid of sales personnel from the Beaumont office were host to more than 250 friends and customers during the one day affair.

Probably one of the smallest offices in the system it is certainly one of the most attractive. The walls are a medium shade of blue-green, and the trim is red and soft yellow. Along part of one wall is a

straight line kitchen display with a range, dishwasher, refrigerator and accompanying cabinets. The range and the refrigerator are connected for demonstrations.

Across part of the back wall is a cashiers counter and behind that two more small rooms for the storage of supplies and service equipment. Across from the kitchen display and around the sales floor are displays of small appliances.

In addition to the local folks who attended the open house there were quite a few out of town guests. Among them were: President Roy Nelson, L. F. Riegel, general sales manager; and E. L. Robinson, Beaumont division manager.

PROMOTED

Last issue we overlooked reporting two promotions which were effective in August and because they deserve mention here they are now.

Perry A. Dickinson was promoted from lineman 1st class to line foreman in Lake Charles on August 1. Perry has been a Gulf Stater since 1941.

Joseph S. Rougeau, Orange, was promoted from serviceman 1st class to service foreman. Perry passed his ten year service mark this September.

James M. Sullivan, formerly truck driver in the Navasota t & d department, was promoted to become labor foreman there on September 18.

ON NEW JOBS

C. L. Fruge, formerly stores truck driver in Beaumont, was transferred to Port Arthur on October 30 where he took over the duties of storekeeper.

Frank G. Dupree, lineman 4th class, was transferred from Conroe to Navasota, effective October 31.

Lineman 1st class Harry Sweaks, who has been working in Conroe, was transferred to Huntsville on November 7 where he will continue to work as a lineman 1st class.

George P. Guins was transferred from Baton Rouge to Clinton on September 12 to become district serviceman for the Clinton area.

Modern Pied Piper

Reeves Garrison Champion Duck Caller



"DUCKY" NOTES SOUNDED as Garrison fanned his fingers to sound one of his champion duck calls in posing for this picture from his Florida Street desk. The duck call he is using here was made by him and won him international honors.

If alarmed customers ever heard a "quack, quack, here and quack, quack there" as they strolled into the Baton Rouge office to pay their bills, it wouldn't necessarily strike a note of "Ol' MacDonald's Farm."

It could as well be Reeves R. Garrison, supervisor of customers' accounting in Baton Rouge, who shelved his conservative personality for a moment to sound off on his homemade duck caller which placed him third in the international duck callers contest held in October at the Crowley Rice Festival.

Garrison, who's been with Gulf States 18 years, vied with 155 contestants at the international match in Crowley where 11 states were represented and there were five state champions.

Calling ducks isn't just a fad, he indicates. He's been at it about 20 years, making the callers, using them and mopping up on his duck limits each season. Already on his first hunt this year he walked away with his day's limit. His hobby nets very favorable results other than actual ducks too. At the Crowley event he received \$250 in war bonds as a prize, and when he placed second in the state at a meet in New Orleans just prior to the international contest, he received \$60 in merchandise.

Apparently making the callers is an art, especially in Garrison's manufacturing processing. He's gained much prominence in the realm of duck hunting, and finds himself each year promising Garrison-made duck calls to numerous acquaintances. He's made several for Beaumont Gulf Staters, all of whom marvel at the job that can be done with reed-cane, a piece of shell and a great deal of technical know-how, all of which in the end is souped in linseed oil to make it waterproof.

Only two classes of people fall for flattery—men and women.



These, gentle readers, are our "Brothers of the Bush" and "Sisters of the Swish", as they were designated during the Montgomery County Historicade during the closing days of October. In everyday life they are the Gulf States Conroe personnel. At top are G. B.

Boswell (inset), Henry Schroeder, Bill Earthman, Alma Coleman, Paul Long and Jean Levert. At bottom is the line crew, in the usual order, Bill Griffith, James Stout, James Carter, B. F. Sparks, L. C. Cummins, Alvin Parker, C. T. Riddel and Charles Turner.



HONORED



Dugas



Wright



Cruise



Nelson



Robinson

Lionel V. Dugas, Beaumont power sales, was elected president of the Petroleum Electric Power Association at its 21st annual meeting held in Beaumont on November 17-18. Lionel has worked diligently in affairs of the association and was elevated from the position of secretary-treasurer to the presidency.

Raymond T. Wright, district superintendent at Huntsville, and an untiring civic worker, was named chairman of the annual Huntsville March of Dimes campaign for the National Foundation for Infantile Paralysis early in December.

Robert B. Cruise, system engineering department, Beaumont, was appointed chairman of the Beaumont American Legion building committee recently. The legion held open house for their new home last month.

President Roy Nelson was named co-chairman of the major gifts committee of the Beaumont YMCA 'Investment in Youth' fund campaign which is now underway. R. J. Orrick, system purchasing agent, is president of the Beaumont YMCA.

Vice President H. C. Leonard, Baton Rouge, was made a director of the Louisiana Safety Association, which held its first statewide board meeting at Baton Rouge on December 2.

Several Gulf Staters were honored recently by being asked to appear as speakers at important meetings held in the area. Each speaker fulfilled his assignment admirably according to reports.

At the national convention of the National Electrical Contractors Association held in Houston November 2-11, Gulf States System Director of Lighting and Municipal Sales Clarence Barron was one of the prominent speakers. His subject was "Planned Lighting"

Beaumont Division Manager E. L. Robinson addressed the Petroleum Electric Power Association meeting at Beaumont. His subject was "How Electric Utilities Have Met the Demand for Power During the Postwar Period."

President Roy Nelson made the welcoming address to this convention. General Sales Manager L. F. Riegel introduced Mr. Nelson to open the meeting speaking schedule.

Married

Charles A. Glover, district serviceman in Gonzales, was married to Katherine P. Picard, home economics teacher at the Live Oak High School, November 27. The couple are making their home in Gonzales.

Julia Thomas, of the electric engineering department in Baton Rouge, became the bride of Allen J. Colomb, employed at Louisiana Station, at quiet ceremonies performed November 13 in New Orleans.

William Lepine, engineering employee in Baton Rouge, was married to June Eggart November 24 at the Sacred Heart Catholic Church of Baton Rouge.

Hazel Brogdon, Baton Rouge, senior customer's clerk, was married October 29 to Thomas F. Clayton, also of Baton Rouge. The couple honeymooned in Dallas, Texas, and are making their home at 4227 Dawson Drive.

Ernest C. Kelly, Baton Rouge line department, was married to Carolyn Glasscock on November 9.

Kathleen Johnson, secretary in the Credit Union office in Baton Rouge, was married to James Singleton on November 23. The couple went to Memphis on their wedding trip.

It's not the size of the boy in the fight that counts so much as the size of the fight in the boy.

On behalf of Gulf Staters Plain Talks extends sympathy to: A. M. Sirman, garage foreman, Beaumont, whose sister, Miss Murl Margaret Sirman died at Conroe on November 12.

Mrs. Fred Cordsen, wife of Fred Cordsen in system engineering at Beaumont, whose father Glen Jernigan died in El Paso October 31. Mr. Jernigan was a former Gulf Stater having been employed at Port Arthur and Lake Charles before transferring to El Paso Electric Company.

Fred Parent, Port Arthur residential sales department, whose father Etienne P. Parent died at Port Arthur on October 31.

Mary Elizabeth Weaver, corporation department, at Beaumont, whose father A. J. Alexander died at Beaumont on November 5.

Jack Burhoe, Beaumont advertising, whose father L. Burhoe, died suddenly at his home in Philadelphia December 9.

A fire breaks out three times a minute in the United States. Fires take a toll of some 10,000 or 11,000 lives in the U. S. alone, or almost one every hour. Be cautious and beware of fires.



PLAIN TALKS CONGRATULATES

Mr. and Mrs. Charles Estes who are the parents of a son, Frederick Allen Estes, born November 27. Charles is in the Navasota Meter Department.

To Mr. and Mrs. E. E. Figari who announced the arrival of a future Aggie November 25. The young man was named John Phillip. His first lineup weight was 7 pounds, 5 ounces.

R. O. Jackson, system consumers accountant of Beaumont, became a grandfather on November 10 with the birth of a son to R. O. Jackson, Jr. who is a dentist in Silsbee.

With the Sick

Plain Talks has a report that Earl Hodge, popular fireman at Riverside Station at Lake Charles, is doing nicely at the Ruston T. B. Hospital where he is undergoing treatment. Earl has expressed a desire to hear from his friends in Gulf States while he is away. Write him, fellows.

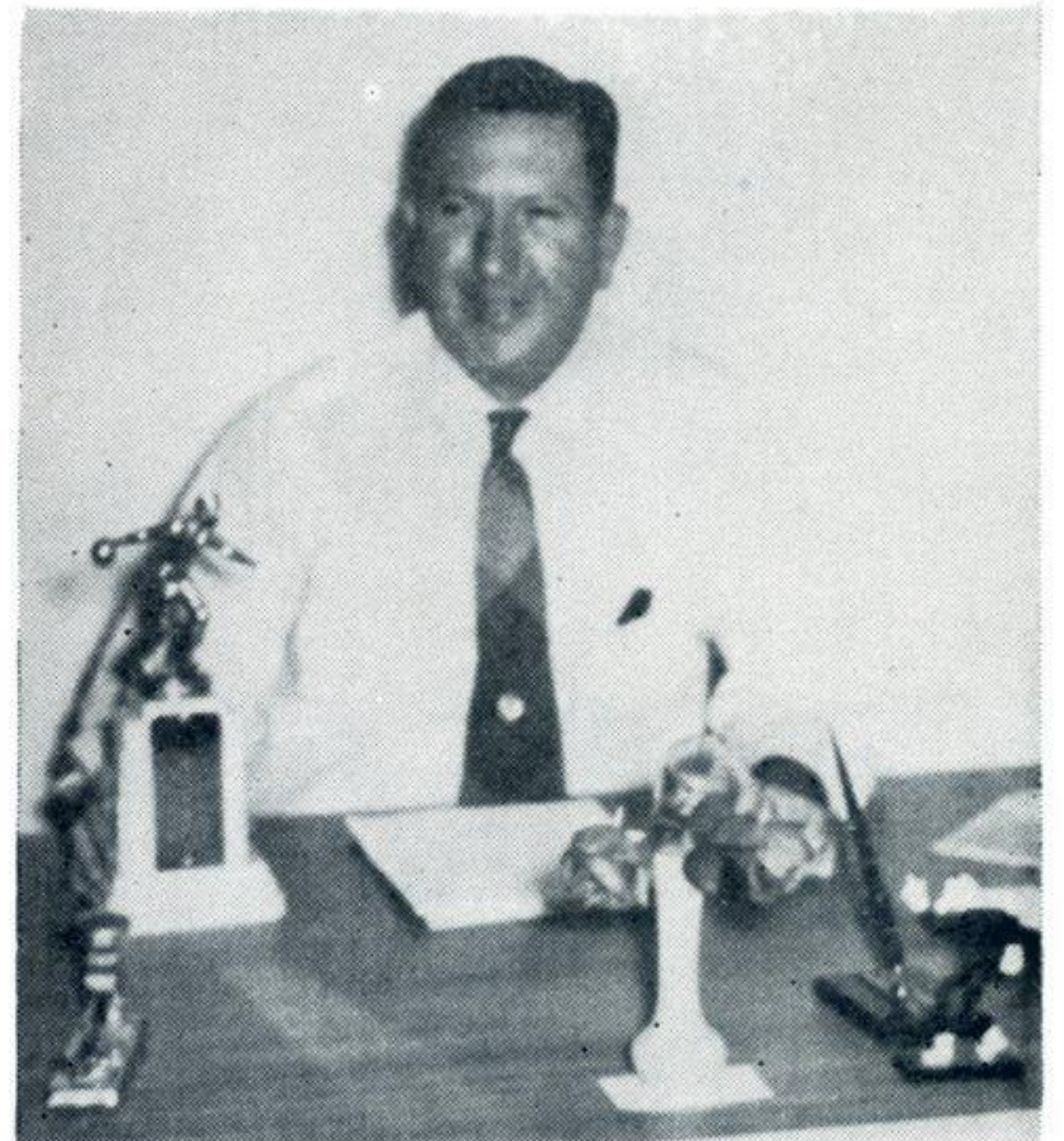

PORT ARTHURIANS claim they do not attempt to do too much flag waving about their many accomplishments—but they do believe they are justified in doing a little bragging about their bowling excellence. Particularly, they say, is this true of their chief clerk, Red Dunham. Hence the picture of Red with his latest trophy, one he won during the summer league which was finished lately. The trophy is a "three-in-one" affair, as the inscription on it reads:

"Summer Major League of 1949—R. W. Dunham—High Average 181—High Series 662—High Game 238."

Red accomplished this same feat while he was located in Beaumont just about two years ago. Evidently Port Arthurians are justified in doing just a little bragging on Red.

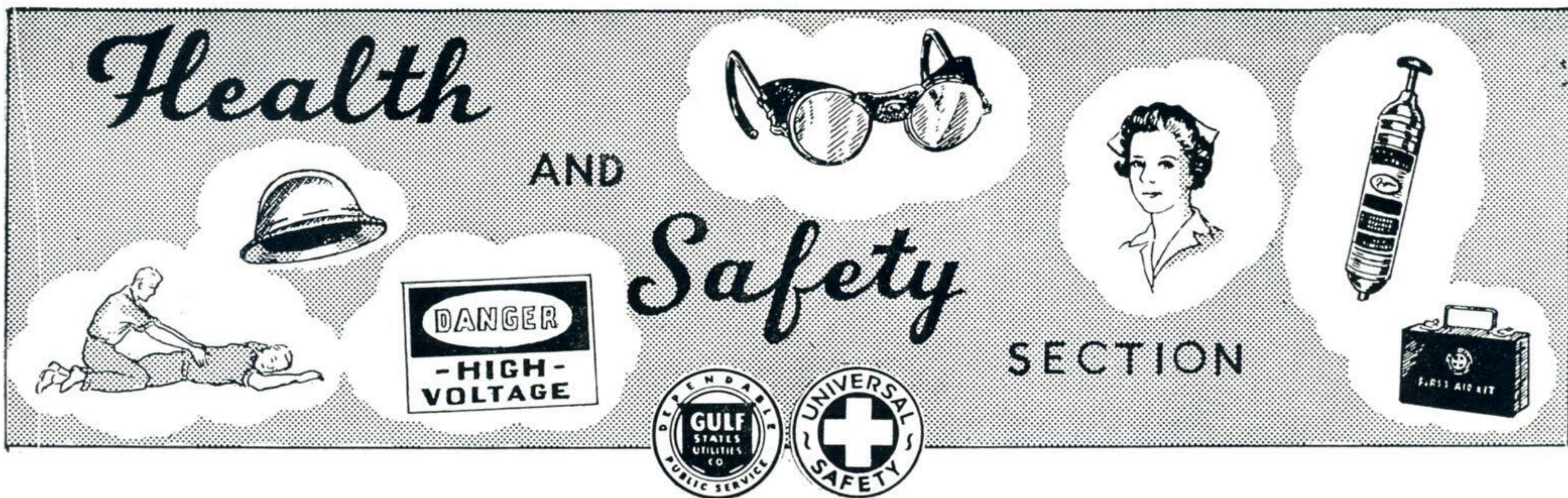

HIGHLIGHTS FROM BATON ROUGE . .

Ample proof that Gulf States is a good place to work is furnished by the two pictures in the lower portion of the page. Snapped at the Baton Rouge gas department safety meeting they show two generations of Gulf Staters from two different families. At left are a father and son combination from the Cowart family—father Julius, gas service man, and son Elvie, gas engineer. At right are the Ackourys—father E. A., tax accountant and son E. A., Jr. gas meter repairman. The picture at the bottom shows another Baton Rouge safety group—one that is in a great measure responsible for the fine safety record Louisiana Station enjoys throughout the years—the safety

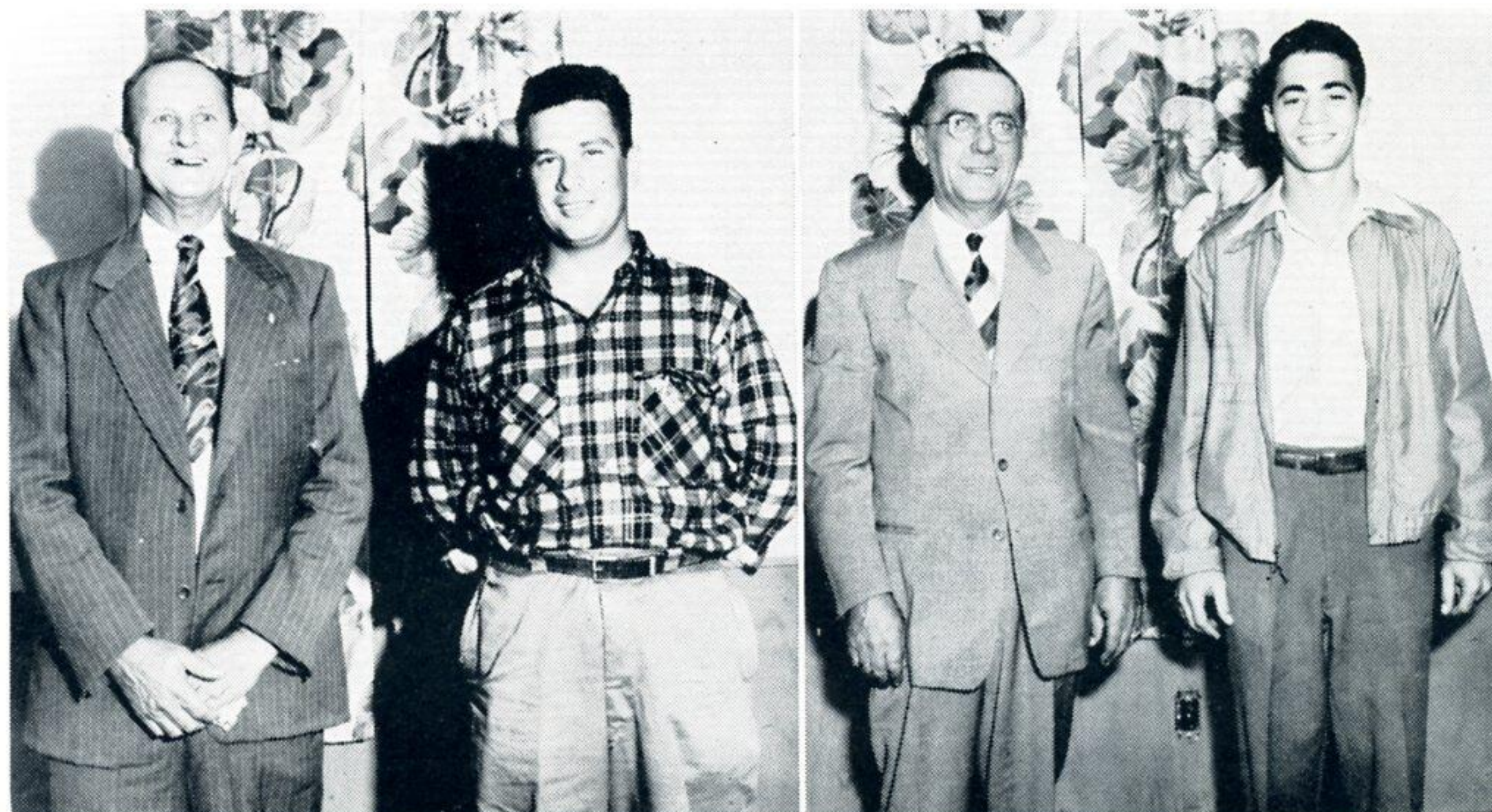

committee. They are, seated, F. L. Amedee, R. E. Kirkwood, L. J. Blanchard, S. J. Laurent, and W. L. Blackwell and G. W. Richardson; standing W. V. Westh and Cyril Dominguez.



Keep the entire holiday season happy . . . Be Merry Safely

Best Wishes from your safety department

*Odus McKnight
Andy Poulson
Jack Shirey*

Scenes from 1949 SAFETY MEETINGS

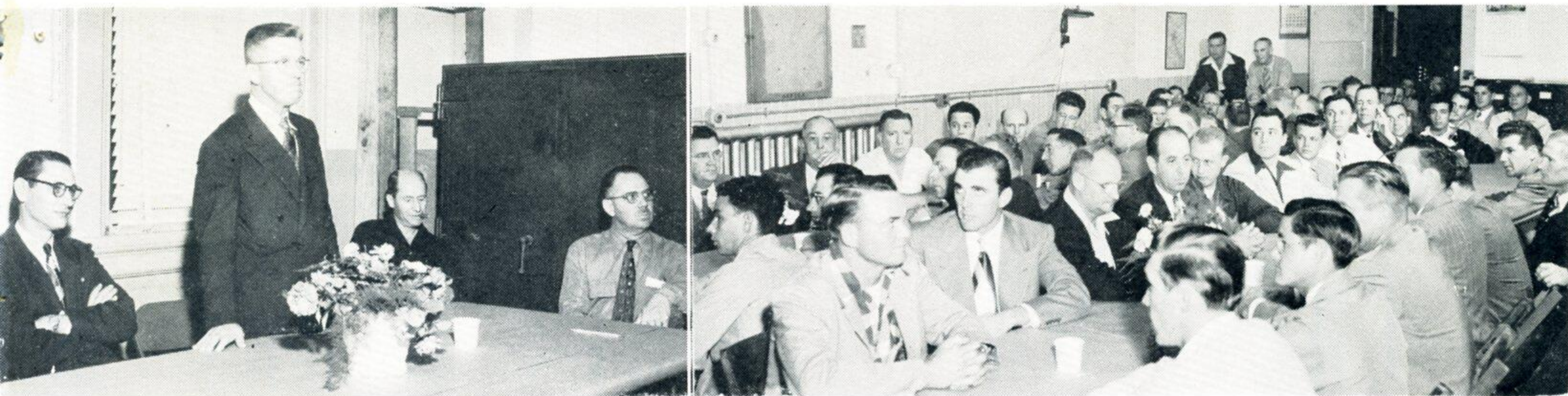

Above are two scenes of Port Arthur's meeting. At left are Andy Poulson, safety representatives; Henry Jouette, Magnolia Refinery safety director, who was the principal speaker; Safety Director Jack Shirey and Division Operating Manager J. B. Hodge. At right are most of the men who attended listening to Mr. Jouette.



These two pictures from the Baton Rouge electric department meeting indicate the two main "dishes" enjoyed before and after the eating. At left are the "Star Dusters" making with the music for the crowd. They are Cyril Sharp, Charles Ruiz, Edward Sanchez, John Chambers and Wallace Felsenthal. All except Sharp are Gulf Staters. At right Vice President H. C. Leonard making the principal talk of the meeting. Also shown are "Uncle Dolph" Delaroderie, F. G. Hornsby, H. J. Ripple and Jim Coltharp.

At least once a year most operating department Gulf Staters manage to get together at the annual Safety meetings. The men look forward to these occasions which are a combination of a brief business session and a long "social" period. The latter item includes visiting and particularly eating. Some of the best feeds seen anywhere are found at these meetings, all of which are informal. Usually each division will have such a meeting. On this page are pictures from the Baton Rouge and Port Arthur divisions.



The Baton Rouge colored employees in the electric, gas and accounting departments joined together for their meeting and as shown a big time was had by all. Fried chicken was the main item on the menu. At left John Deemer, oldest colored employee in the division (40 years) is speaking to the group on the importance of SAFETY. In background at right are R.O. Wheeler, J. C. Spengler and A. G. Delaroderie who also spoke briefly.



Keep Your

CHRISTMAS HOLIDAY MERRY

PLAY SAFE

The Fourth of July used to have the highest rating for holiday fire accidents. Because so many precautions have been enforced to make the Fourth of July safer, the accident quota for this summer holiday has dropped way down, and in comparison the Christmas day toll has gone up. By using similar caution on December 25th the number of fire tragedies on this day also can be reduced. Here are a few do's and don't's for you to follow:

DON'T buy your children toys which use alcohol, kerosene or gasoline to make them go.

DON'T place electrical trains around the base of a tree.

DON'T leave the tree lights burning when you are away from the house.

DON'T use candles.

DO inspect your wiring before attaching lights to Christmas tree.

DO be sure that all electrical toys you buy have the Underwriters' Laboratories Inc. makers on them.

DO be sure you have plenty of ashtrays around your house so stray ashes or cigarettes won't cause a fire.

DO use non-inflammable decorations on your tree.

DO call the fire department immediately upon detecting fire.

DO have emergency equipment easily available for controlling small fires.

DO have a pail of water near your tree for immediate dousing of the tree.

DO have an Ansul Dry Chemical Fire Extinguisher near your electric outlets for immediate control of electric fires.

